

## Model 754 Electronic Tape Dispenser



### BP754 OPERATING MANUAL

**This manual is a non-controlled document.**

Information in this manual does not constitute a warranty of performance. Furthermore *Better Packages* reserves the right to revise this publication and make changes from time to time, in its content.

***Better Packages* ASSUMES NO LIABILITY WHAT SO EVER FOR ANY LOSSES OR DAMAGES INCURRED AS A RESULT OF INFORMATION CONTAINED IN THIS MANUAL**

**Proprietary Notice**

This publication contains information proprietary and confidential to Better Packages. Any reproduction, disclosure, or use of this publication is expressly prohibited except as Better Packages may otherwise authorize in writing.

## TABLE OF CONTENTS

<b>Safety Precautions</b> . . . . .	<b>Page 4</b>
<b>Technical Data</b> . . . . .	<b>Page 5</b>
<b>Unpacking Notes</b> . . . . .	<b>Page 6</b>
<b>Preparing the Machine for Operation</b> . . . . .	<b>Page 7</b>
<b>Operating Instructions</b> . . . . .	<b>Page 11</b>
<b>Recommended Maintenance</b> . . . . .	<b>Page 13</b>
<b>Warranty Statement</b> . . . . .	<b>Page 15</b>

## **SAFETY PRECAUTIONS**

***Must read before servicing equipment.***

**Always unplug the machine before performing any maintenance or repair.  
Line voltages may be present even with power switch in Off position.**

- This machine is designed for sealing cartons with water activated tape. Any other use will void all warranties and any responsibility or liability of *Better Packages, Inc.*
- Read all Safety Precautions and Operating Instructions before powering on and using the machine.
- Any operator of this machine must be fully trained in the operation and safety.
- In the event of a malfunction or breakdown, grounding provides a low resistance path for electric current to reduce the risk of electric shock. This machine is equipped with an electric cord having an equipment-grounding conductor and a grounding plug. The plug must be plugged into a matching outlet that is properly installed and grounded in accordance with all local codes and ordinances.
- Before connecting the machine to the power mains verify that the electrical ratings of the machine match the electrical supply intended for connection, otherwise do not connect. If the correct power is not available contact the reseller.
- The electrical safety of this machine is guaranteed only when it is correctly connected to a grounded electrical system as prescribed by the present electrical safety rules.
- Before maintenance or repair, disconnect the power cords from the electrical supply and protect the cables from any possible accidental connection carried out by unauthorised personnel.
- Keep the machine away from children and from personnel who are not authorised or adequately instructed in the use of it.

## TECHNICAL DATA

<b>Size:</b>	21"L x 10.5"W x 9.5"H
<b>Dispensing Speed:</b>	Up to 32" per second
<b>Water Bottle Capacity:</b>	1.1 quarts
<b>Tape Width:</b>	1" to 4" Wide
<b>Maximum Roll Size:</b>	Up to 600 ft. of tape Up to 7.5" diameter roll
<b>Tape Lengths Dispensed:</b>	6" to 100" plus unlimited random lengths
<b>Shipping Weight:</b>	42 lbs.
<b>Power Requirements:</b>	115 volts, 60 Hz, 3 Amps

All specifications subject to change without notice.

## UNPACKING

When unpacking your new Better Pack Electric machine, check to make sure you have the following items before discarding packing material:

- Water Bottle (Under Left Side Cover)
- 2 Tape Roll Guides
- Water Tank and 2 Brushes
- Upper Tape Plate

**Note:** The upper tape plate is held in position by packing materials but may have been dislodged in shipping. Remove all packing material before using machine.

Cut off and remove the plastic ty-rap used to secure the blade during shipping (see picture below).

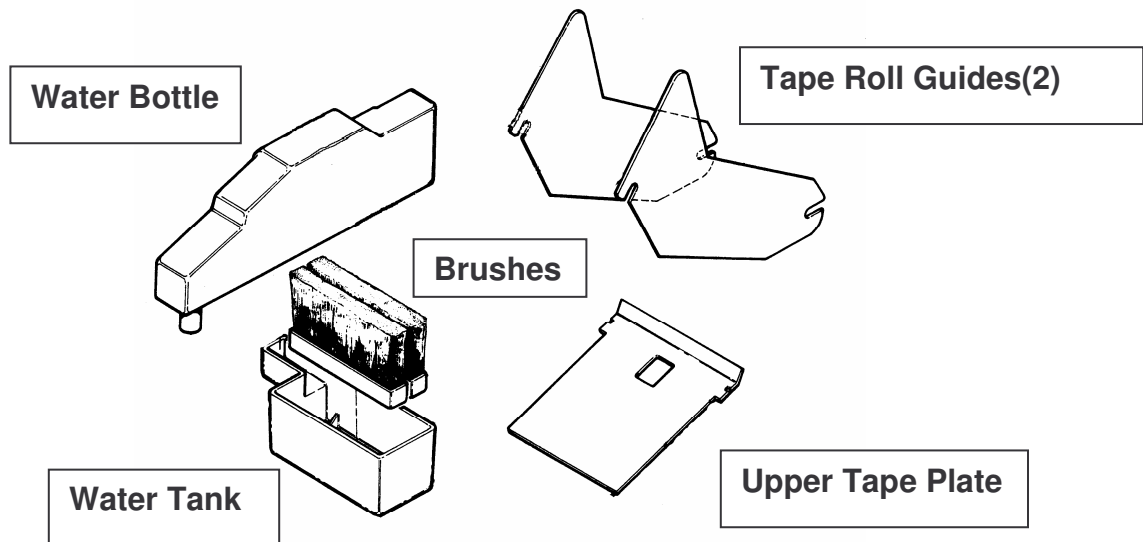

Cut and remove ty-rap



## PREPARING THE MACHINE FOR OPERATION

1. If the upper tape plate has been dislodged in shipping, replace as follows. With the center slot toward the front of the machine, slide under feed wheel shaft from the rear until the cut-out portions on sides are over the retaining "buttons". Drop plate and slide forward so that end of plate is under the rod just to the rear of the shear and the back end is under the "buttons".

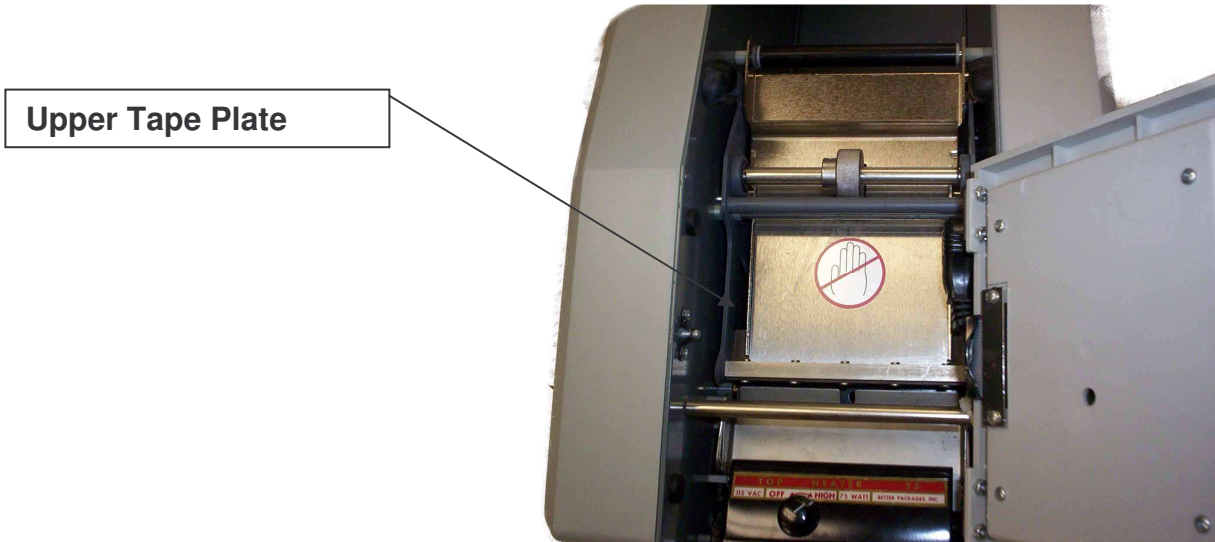

2. Remove tank and brushes. Wash brushes thoroughly in warm water and soap or mild detergent. Replace brushes in water tank. Note the two brushes are beveled. Replace them in tank, being sure each brush is positioned with the high side toward the front of the tank. Replace tank and brushes in the machine.

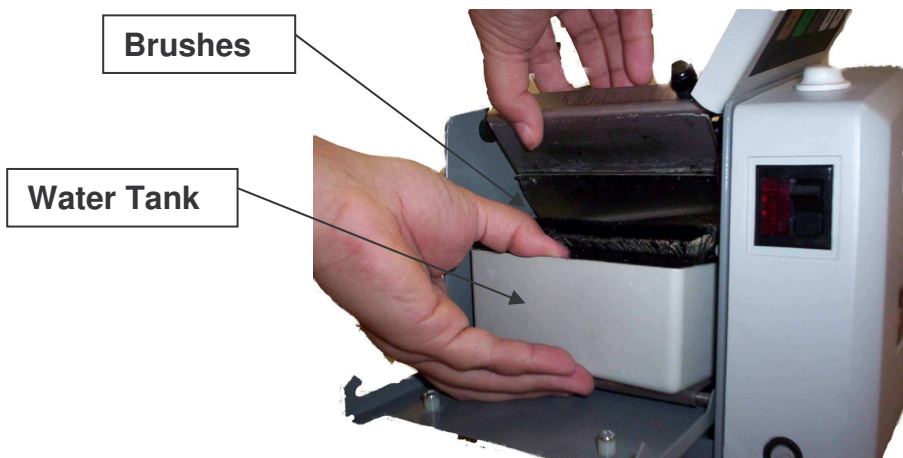

3. Fill bottle with water and place in bottle holder so that the spout of the bottle is in the tank. Set correct water level (please read below).

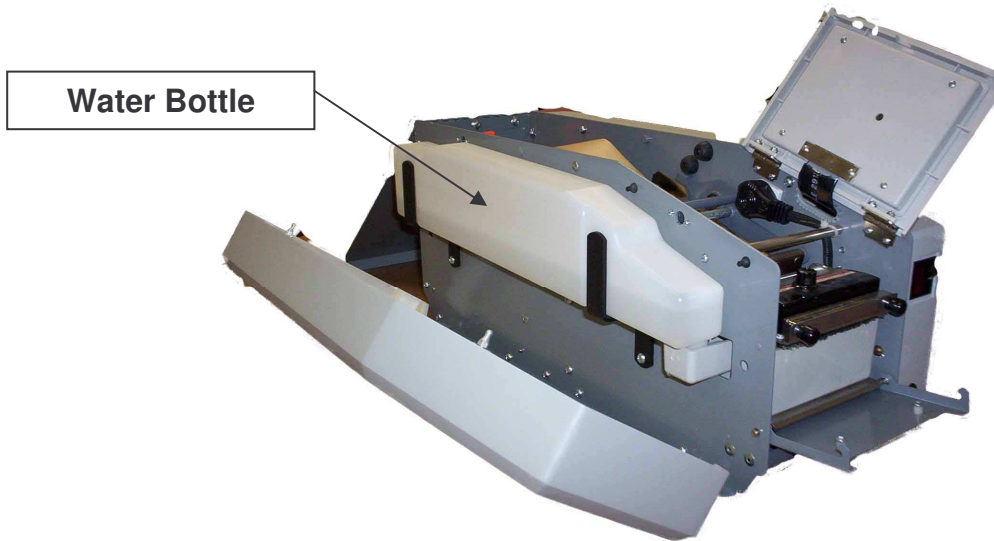

The amount of water required for proper moistening of different grades and types of tape will differ. Heavier adhesives on reinforced tapes will normally require a high water level. Lighter tapes require less water and a lower level.

The water level is controlled by the position of the front water bottle bracket. To adjust the water level, loosen the two screws on the bottle bracket, move to the desired position and tighten both screws.

4. Adjust roll guides inside rear of machine to proper width for tape.



The tape roll guides in the tape basket should be properly set for the widths of tape being dispensed. The roll of tape should preferably be centered between the frames by confining the tape loosely between the roll guides which engage in between the spring loaded spacers on the tie rods.

To set the roll guides in position, lift them out, move to the desired position and re-insert.



5. Loading Tape (wound adhesive side in). Take the roll and unwind about 18". Place the roll in the basket so that the strip unwinds off the rear of the roll as the leading end is brought up toward the front of the machine with the adhesive side down. Thread tape over the roller at the upper rear and slide leading edge forward under upper tape plate and feed wheel.

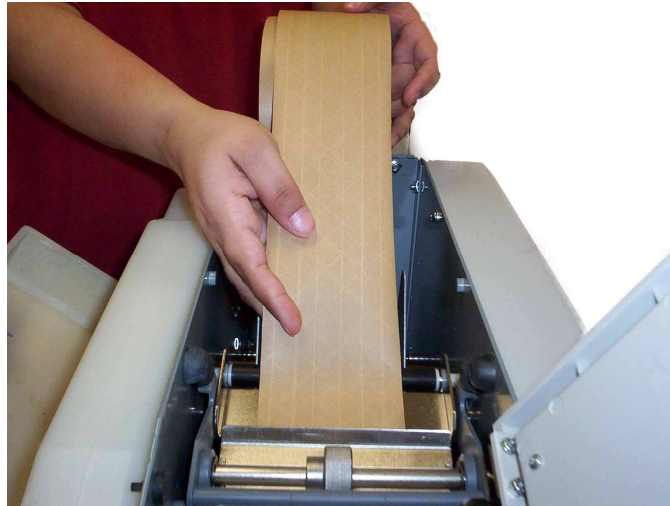

## 7. Electrical Connection

- a. Plug machine into 115 volt 60 Hz current only.  
**WARNING**

**FOR YOUR SAFETY** all the metal parts of this machine are electrically grounded through a 3-wire power supply cord and a 3-prong grounding type plug which must be plugged into a 3-wire grounded type receptacle.

If you are not sure the electrical system in your building is properly grounded, call a licensed electrician.

- b. When all connections have been made, turn on the power switch at the right front of machine. Pilot light should light and indicates the machine is ready for operation.

## 8 Adjustable Moistening

To give the most efficient moistening for all kinds of tapes, your machine is equipped with an adjustable water level and adjustable weights on the thermostatically controlled top heater and pressure plate assembly.

Increasing the height of the water level increases the amount of water applied to the tape.

Increasing the weight on the top heater and pressure plate assembly also has this effect plus the more even spreading of water on the tape. The weights (three in number) are attached to the front end of the top heater and pressure plate assembly and held in place by two screws. To remove, loosen the screws slightly and lift out the weights as required. Lightest pressure is with all weights removed. Maximum pressure is with all weights in place.

For example, certain paper tapes have adhesive which normally requires somewhat less water for best moistening results. With such tapes very little weight is required and all weights at front of pressure plate and top heater assembly are generally removed. Other tapes requiring slightly more water usually work best with the medium weight pressure. Only one or two weights should be used at the front of the top heater and pressure plate assembly.

Other tapes may have as much as two or three times the amount of adhesive to be moistened.

## 9. Top Heater Settings

Finding the correct setting for the tape you are using is a matter of simple testing. Turn the adjustment knob (clockwise) to the highest setting, then back off slightly to the lowest temperature setting that best meets your needs.

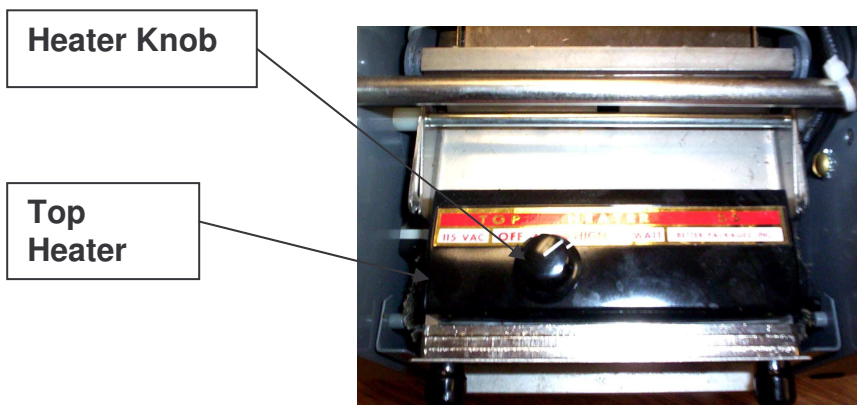

## OPERATING INSTRUCTIONS

1. After following the setting up instructions and adjusting the machine for correct water level, pressure plate weight and top heater temperature, load machine with tape and you are now ready to operate the machine.
2. To feed tape, adjust the dial for the length of tape you wish to dispense, lightly press the dispensing buttons. There are two adjusting dials so that you can program two different lengths of tape at one time. This allows you to prepare an "H" pattern for the length and width of the carton.
3. **RANDOM LENGTHS** - This key at the right front of the machine is for visually measured lengths of tape. If the key is held down, excessive length of tape is dispensed. With a little practice, the operator can quickly develop his "time" sense and dispense lengths with considerable accuracy.
4. **DELAY CONTROL** – Set the delay time so that the machine waits before automatically dispensing the next length of tape. The delay can be set from approximately 1 to 30 seconds.
5. **OPERATOR MODE SELECTION** – Choose the operating mode for the machine by positioning the mode selector switch to MAN (manual), AUTO (automatic), or 1-2-2, as appropriate.
6. **MANUAL MODE** – Tape is dispensed immediately each time a dispense key is pressed.
7. **AUTO MODE** – The automatic mode dispensing sequence is started by depressing a dispense key. The tape length is set by the length dial above the key pressed. The machine waits the set delay time after the operator removes tape and then automatically dispenses the next piece of tape. The same length is repeated until either the other dispense key is pressed or the mode is changed.
8. **1-2-2 MODE** – The 1-2-2 mode dispensing sequence is started by moving the mode selector switch from MAN to the 1-2-2 position and then depressing the left dispense key. The 1-2-2 dispensing sequence begins by dispensing a length set by the left length dial and then 2 lengths of tape set with the right length dial. The dispenser waits the set delay time after the operator removes the tape and then automatically dispensing the next piece of tape. The 1-2-2 sequence repeats until the mode is changed.

**Note: If the machine does not dispense tape when in "Auto" or "1-2-2" modes, check to make certain there is no tape stuck in the machine blocking the tape sensor. IR (invisible) light is emitted from a small hole on the bottom side of the keyboard and is sensed by a IR phototransistor down in the machine slightly forward of the cutting blade. If a piece of tape is blocking the light path, the machine does not know a tape piece has been removed, so it does not dispense the next piece. Remove the tape to fix the problem.**

9. **RANDOM LENGTHS** – The random key at the right side front of the machine is for visually measured lengths of tape. The machine dispenses tape as long as the key is held down. Always hold the key down long enough to allow the tape to extend out of the machine. Short pieces of tape which do not extend out and are left in the tape path can block the photo sensor. If the sensor is blocked, the machine will not operate properly in the automatic or 1-2-2 pattern modes. Shut the machine off and remove the piece of tape from the machine if this happens. The photo sensor is below the tape path in front of the cutter.

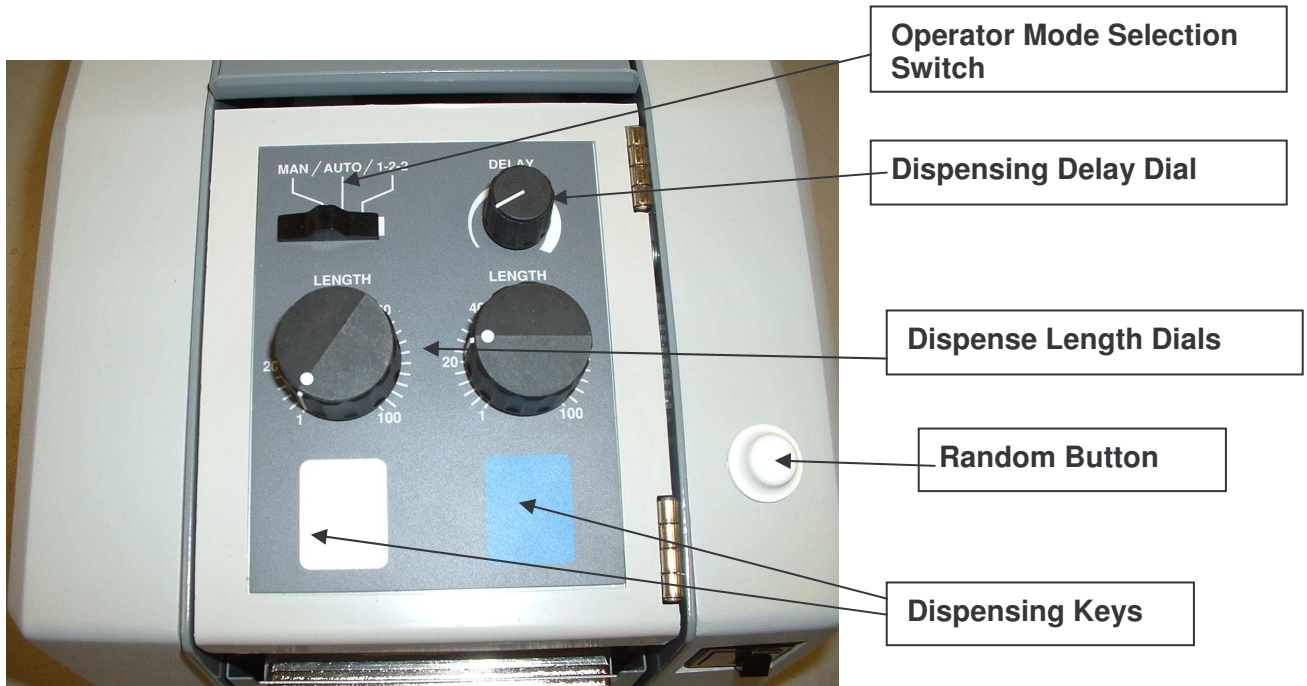

## Recommended Maintenance

### Clean Brushes

Clean the brushes on a weekly basis or when adhesive build up effects proper moistening of the tape. The adhesive can prevent sufficient and even water flow to the tape causing poor moistening of the tape. Regular cleaning will extend the life of the brushes and insure that adhesive build up will not cause performance to deteriorate.

Procedure:

1. Unplug power from the machine! Remove the water bottle and water tank. Twist the tank up over the lip on the tank shelf which prevents it from sliding out of the machine.

***Caution: Heater may stay hot for a period after machine is off.***

Remove the brushes from the tank to remove any dried adhesive. You will need to tilt the brushes to clear the retaining bracket. Notice how the brushes are positioned in the tank because the must be replace correctly.

2. Wash the brushes with warm water and soap.
3. Place the brushes back into the water tank. It is extremely important that they are positioned correctly. Brushes must be sloped toward the front of the dispenser in order to work properly. The top of the brushes are cut at an angle. Shorter brushes go in the back. The longer length bristles must be toward the front of the machine (tank).

Notice: Installing the brushes backwards will cause excessive tape jams.

Never cut the brush tips to remove adhesive as they are cut at a specific angled and flagged to facilitate proper moistening and cutting will most likely cause poor performance

### Cleaning the Shear Blades

When using reinforced tapes laminated with adhesive or resin, this material can accumulate on the blades and interfere with cutting the tape. Even paper tape with no reinforcement can cause an accumulation of dust and adhesive on the blades.

Use a small brush and a suitable solvent to remove accumulation.

Never scrap the cutting edge with a hard object because the blade may become dull and need replacement.

***Warning: Be sure the dispenser is UNPLUGGED before performing any cleaning procedures.***

## General Machine Cleaning

The feed wheel pushes tape through the machine. Obstructions such as dirt or dried adhesive can divert the tape and cause it to jam. Periodical cleaning the tape path will mitigate tape jams.

### Procedure

1. Remove the upper tape plate that sets on the tape next to the feed wheel. Pull tape off from the lower tape plate if it hasn't already been removed. Clean any dirt and adhesive from the upper and lower tape plates.
2. Lift the heater up and clean the bottom of it. Under the heater is a J-plate that the tape rides over. The J-Plate and heater plate are separated by a small gap that helps the tape to move under the heater and onto the brushes with minimal obstruction. Pull down on the front of the J-Plate to separate it from the heater plate. Clean between the plates then snap the J-plate back onto the heater plate. Be careful not to bend the J-plate. A bent J-plate can be a cause of tape jams.

## LUBRICATION

1. All vital moving parts of this machine have oil retaining porous bushings and should not require additional oil for the average life of the machine.
2. **FEED WHEEL SHAFT** - Do not oil this shaft. Oil can creep in through the bearings and effect internal parts.

## Better Packages, Inc. Warranty Information

### Limited Warranty Statement

The manufacturer warrants each new Better Packages machine and accessory to be free from defects in material and workmanship under normal and proper use, its obligation under this warranty being limited to replacing or repairing any defective parts within the time period indicated for the specific model after delivery (at the company's discretion) to the customer. Wearable parts such as shear blades, springs, water brushes and motor brushes are not covered under the warranty. Machines used for any reason not intended by the manufacturer will not be considered for warranty protection.

The company will replace or repair (at the company's discretion) any defective parts within the warranty period, on a no-charge basis. The Authorized Distributor/Service Center will furnish, without charge, within the time period indicated for the specific model, necessary labor to service the machine.

If customer wishes, they may forward their machine (excluding case sealers) with authorization to Better Packages or an Authorized Distributor/Service Center for warranty service. Any item shipped for warranty service must be shipped in the original factory carton and properly packed with the original protective packaging inserts or a secure carton that will properly protect the unit during transit. Units received improperly packed are subject to costs associated with damage caused during transit. These costs will be the responsibility of the customer. All associated shipping or freight costs related to items shipped for service are the sole responsibility of the customer.

For service under this warranty, call or write your nearest Better Packages Distributor/Service Center or Better Packages, Inc. Shelton, CT at 800-237-9151. Transportation charges on machines or parts returned to Better Packages for service must be prepaid by the customer. Customers will be responsible for freight expenses on parts or machines returned to them.

### Product Warranty\*

Model	Parts	Labor
Better Pack® 755 Series	2 Years	6 Months
Better Pack® 754 Series	2 Years	6 Months
Better Pack® 555e series	2 Years	6 Months
Better Pack® 500 series	2 Years	6 Months
BP Sealmaster® 3000 CS & 3000 AFF	1 Year	6 Months
Better Pack® 333 Series	2 Years	6 Months
TapeShooter® 150	2 Years	6 Months
TapeShooter® 404	2 Years	6 Months
Packer® 3S	2 Years	6 Months
Better Pack® PS2A	1 Year	6 Months

**\*When servicing a Better Packages product, genuine Better Packages replacement parts should be used. Any other parts used will void all existing warranties and any UL, CE and CSA certifications and may create a safety hazard.**

Visit [www.betterpackages.com](http://www.betterpackages.com) to locate your local Authorized Distributor/Service Center



This warranty statement dated January 1, 2007 supersedes all other prior published statements.